

## DESARGUES CONFIGURATION AND ELECTRICAL NETWORKS/CIRCUITS

S. Sheeba<sup>1</sup> & B. R. Srinivasa<sup>2</sup>

<sup>1</sup>Research Scholar, Department of Mathematics, JAIN University, Bangalore, Karnataka, India

<sup>2</sup>Research Scholar, Department of Mathematics, Kongadiyappa College, Bangalore, Karnataka, India

### ABSTRACT

An electronic network /circuit consists of components like resistors, diodes, capacitors, transistors and ICs, arranged such that the network contains maximum number of components using minimum space. When translated into geometry, this results in an arrangement of lines and points called **CONFIGURATION**. Thus, the geometrical configuration finds its natural application to circuit theory through network topology[1][network topology is the geometrical relationship between the electrical components that are to be equipped in the network]. Moreover configurations may be used to represent electrical components equipped in the network. **For instance, an  $n_1$  configuration, is a resistor (or capacitor, inductor, diode or a battery (source) ) when  $n = 2$ , a transistor when  $n = 3$  and an IC when  $n > 3$ .** In this paper, we demonstrate as to how a certain configuration results in a working model called “Boot strapped emitter follower as Colpitt’s oscillator”. In this paper, we also recall the definitions of “**perspective from a point (PFP) and perspective from a line(PFL)**” and define these concepts in terms of physical facts “**Projection, reflection and refraction**” and translate these to circuits. In this paper, we also demonstrate as to how perspective from a point results in a series circuit and perspective from a line results in a parallel circuit.

**KEYWORDS:** Configuration, Desargues Configuration, Multi – Vertixed /Hyper Edge Grap Perspective from a line(PFL), Perspective from a Point(PFP)

---

### Article History

**Received: 06 Jan 2018 / Revised: 23 Jan 2018 / Accepted: 05 Feb 2018**

---

## INTRODUCTION

### Section 1

In this paper, we see how configuration of points and lines find its natural application in circuit theory. A circuit is an arrangement of terminals (points) and components (lines) and hence a configuration in terms of geometry. To effectively arrange maximum components in an electrical network/ circuit using minimum space requires the study of configuration and results on them. There are many types of configurations and theorems on them, not all of them find application in circuit theory. However, a few of them can be effectively applied to circuit theory. The most important configuration which finds its application is **Desargues configuration**.

This paper is organized into 6 sections. In section 2 we recall some definitions of configuration, Perspective from a point (PFP) and Perspective from a line (PFL). In section 3 we interpret the definitions of PFL and PFP in terms of simple physical facts Projection, Reflection and Refraction and then translate them in terms of graph theory. In this section, we translate given configurations to their corresponding graphs and define PFP and PFL in terms of graphs.

We see that the representation of any configuration in terms of graph requires an altered definition of an edge. Hence we define Multi vertexed /hyper edge graph , recall the definition of a hyper graph and state the differences between them. In section 4 we translate the concepts of configuration, Perspective from a point (PFP) and Perspective from a line (PFL) in terms of the electrical network / circuit. In section 5 we apply some results on configuration, in particular Desargues configuration to electrical network/circuit followed by the conclusion in section 6.

## Section 2

In this section, we list various types of configurations and examine them for their application to circuit theory. For this purpose, we recall some standard definitions, modify them whenever necessary so as to apply it to circuit theory.

### Definition 2.1 Configuration/ Symmetric Configuration [6]

A configuration is an arrangement of ' $p$ ' points and ' $l$ ' line such that ' $m$ ' lines ( $l > m$ ) among them pass through each of ' $p$ ' points and ' $n$ ' points ( $p > n$ ) lie on each of ' $l$ ' lines . This is called a  $(p_m, l_n)$  configuration. A configuration in which

' $p = l$ ' and consequently ' $m = n$ ' is called a symmetric/ balanced configuration denoted by  $p_m = (p_m, p_m)$ .

Let us illustrate configuration/symmetric configuration by the following examples.

#### 2.1 (a) Examples of Symmetric Configuration

##### Example 1: A $1_1$ Configuration

A  $1_1$  configuration is the simplest possible symmetric configuration with a point incident on a line and a line passing through one point.



Figure 1: A  $1_1$  Symmetric Configuration

##### Example 2

If given two points and two lines, the possible arrangements of points and lines are  $2_1$  and  $2_2$ . But we see that the only possible arrangement is  $2_2$ . This arrangement is a  $2_2$  symmetric configuration with 2 points and 2 line such that 2 lines among them pass through each of 2 points and 2 points lie on each of 2 lines as shown in the figure



Figure 2: A  $2_2$  Symmetric Configuration

##### Example 3

Similarly, given three points and three lines, the possible arrangements of points and lines are  $3_1$ ,  $3_2$  and  $3_3$ . But we see that the only possible arrangement is  $3_2$ . This arrangement is a  $3_2$  symmetric configuration with 3 points and 3 line such that 2 lines among them pass through each of 3 points ( $3_2$ ) and 2 points lie on each of 3 lines ( $3_2$ ) as shown in the figure. This  $3_2$  symmetric configuration represents a simple triangle.

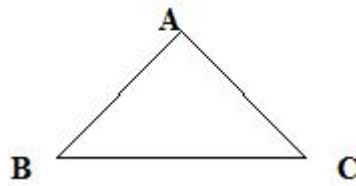

**Figure 3: A  $3_2$  Symmetric Configuration**

The following are examples of symmetric configurations that are obtained from the possible arrangement of ‘p’ points and ‘l’ lines.

**Example 4: A  $9_3$  Configuration (The Pappus Configuration )**

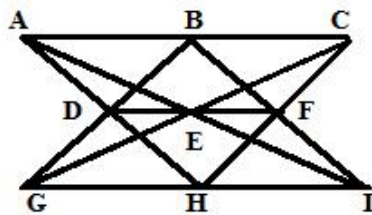

**Figure 4: A  $9_3$  Symmetric Configuration**

**Example 5: A  $10_2$  Configuration**

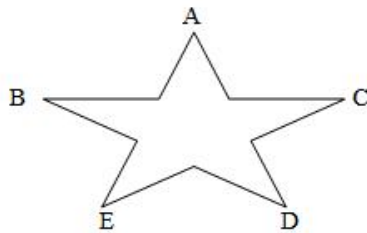

**Figure 5: A  $10_2$  Symmetric Configuration**

**Example 6: A  $10_3$  Configuration (The Desargues Configuration)**

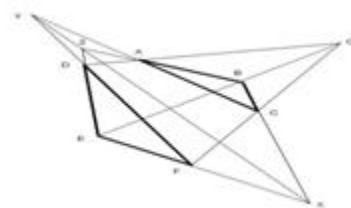

**Figure 6: A  $10_3$  Symmetric Configuration**

**Note**

- Given ‘p’ points and ‘l’ lines ( $p_1, p_2, \dots, p_l$ ) are the possible arrangements, but not all the arrangements can be translated as symmetric configurations .
- In this view, we see that it is difficult to visualize symmetric configuration when  $p = l = m = n$  for  $p > 3$ .

## 2.1 (b) Examples of $(p_m, l_n)$ Configuration

### Example 7: A $(4_3, 6_2)$ Configuration

A  $(4_3, 6_2)$  Configuration is a configuration with 3 lines passing through each of 4 point ( $4_3$ ) and 2 points lie on each of 6 lines ( $6_2$ ). This configuration represents a complete quadrangle.

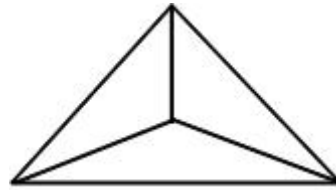

Figure 7: A  $(4_3, 6_2)$  Configuration

### Example 8: A $(6_3, 9_2)$ Configuration

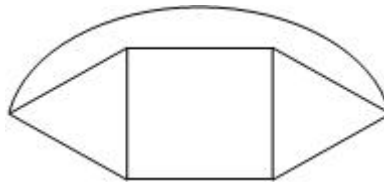

Figure 8: A  $(6_3, 9_2)$  Configuration

The above examples on configuration and in particular Desargues Configuration show their natural application to circuit theory. The existence of Desargues configuration of 10 points and 10 lines with 3 points per line and 3 lines per point is given by “*Desargues Theorem*”, stated in terms of PFP and PFL to be defined later.

**Desargues Theorem[3]:** Two triangles are in perspective axially (PFL) if and only if they are in perspective centrally (PFP)

The Desargues theorem is based on two important aspect: “*Perspective from a point*” (PFP) and “*Perspective from a line*” (PFL). In this direction we recall the definitions of corresponding points and lines to define the concepts of “*Perspective from a point*” (PFP) and “*Perspective from a line*” (PFL) .

### Definition 2.2: Corresponding Points/Lines

Let  $X$  and  $Y$  be two sets of points. Let  $f: X \rightarrow Y$  be a mapping such that  $f(x) = y, x \in X, y \in Y$  then the points  $x, y$  are called the corresponding points. If  $X$  and  $Y$  are subsets of the plane, then the lines passing through the corresponding points are called corresponding lines, then the sets  $X$  and  $Y$  are called the corresponding sets.

**Example:** Let  $X = \{a, b, c\}$  and  $Y = \{p, q, r\}$  be two sets of 3 points Let  $f: X \rightarrow Y$  be a mapping such that  $f(a) = p, f(b) = q$  and  $f(c) = r$ , then the points **a,p, b,q** and **c,r** are called corresponding points. Let  $l_1, l_2$  and  $l_3$  be the corresponding lines passing through the corresponding points **a,p, b,q** and **c,r**. Thus the sets  $X$  and  $Y$  with corresponding points **a,p, b,q** and **c,r** and corresponding lines  $l_1, l_2$  and  $l_3$  are called corresponding sets.



We say that the ‘n’ sets are perspective from a point ‘p’ if all the corresponding lines are concurrent with the point ‘p’. The point ‘p’ is called centre of perspective.

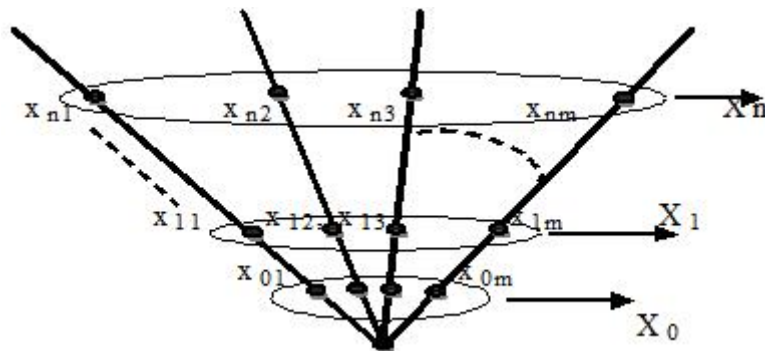

**Figure 11: ‘n’ Sets of ‘m’ Corresponding Points are PFP ‘p’**

**Note**

Two sets of corresponding points are said to be PFP if the corresponding lines are concurrent at ‘p’, but in many situations it may not be concurrent. In such cases we verify whether the corresponding lines meet a single line L at different points. This leads to perspective from a line(PFL) as shown below.

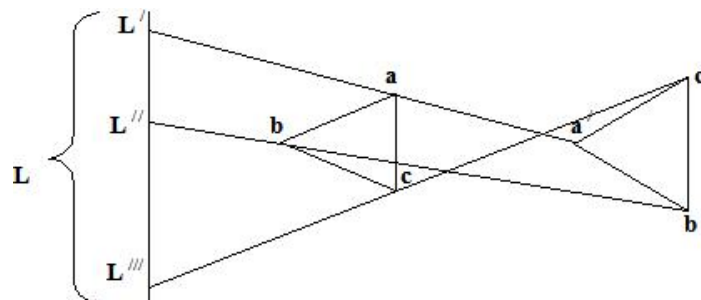

**Figure 12: Two Sets X and Y of 3 Points are PFL**

In the above example the corresponding points meet along a line L.

**Definition 2.5: Perspective from a Line (PFL) for Two Sets of Points**

If  $X = \{ a, b, c \}$  and  $Y = \{ a', b', c' \}$  be two sets of 3 points, then we say that the two set X and Y are PFP ‘p’ if the corresponding lines  $l_1, l_2$  and  $l_3$  passing through the corresponding points  $(a, a'), (b, b')$  and  $(c, c')$  meet at different points  $L', L''$  and  $L'''$  on the line L.

Now let us how these concepts, Perspective from a point(PFP) and Perspective from a line (PFL) can be defined in terms of simple physical facts **“Projection, Reflection and Refraction”**.

**Definition 2.6: Projection**

Let L be a line through a point ‘p’, then we say p is projected along L.

**Definition 2.7: PFP in Terms of Projection**

Let a point ‘p’ be projected along ‘m’ lines  $l_1, l_2, \dots, l_m$ . Let  $(a_1, a_2, a_3, \dots, a_m)$  and  $(b_1, b_2, b_3, \dots, b_m)$  be points such that they lie on the lines  $l_1, l_2, \dots, l_m$  respectively as shown in the figure below. The sets  $X = (a_1, a_2, a_3, \dots, a_m)$  and

$Y = (b_1, b_2, b_3, \dots, b_m)$  are automatically PFP 'p'. In fact all sets of points on these lines are PFP 'p'.

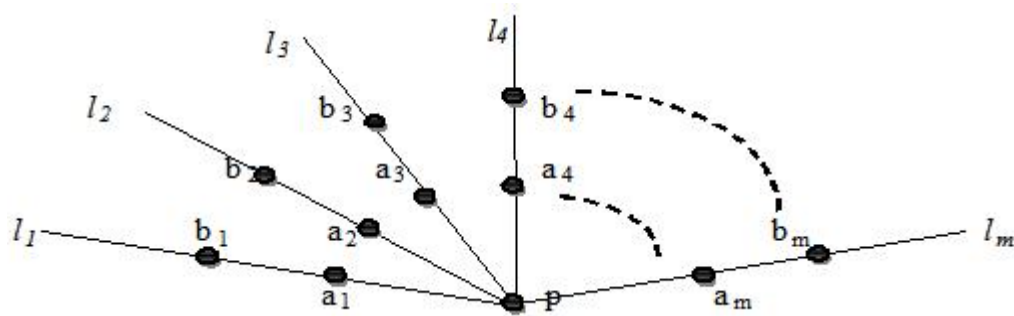
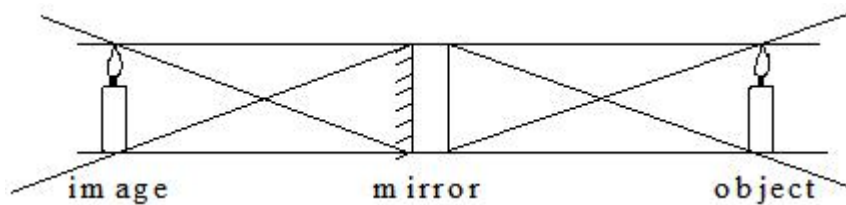

**Figure 13: 'm' Projected Lines are PFP 'p'**

We say that the above points are PFP 'p' if the points  $(a_1, b_1)$ ,  $(a_2, b_2)$ ,  $\dots$ ,  $(a_m, b_m)$  are distinct. On similar lines we can generalize the definition for PFP in terms of projection for 'n' points on 'm' lines.

**PFP/PFL in Terms of Reflection and Refraction (Mirror)**

When an object is placed in front of a mirror and a light source is projected on the object, the reflection of the object is seen behind the mirror. Let  $X = \{ B_O, T_O \}$  where  $B_O$  is the base point of the object,  $T_O$  is the tip point of the object and  $Y = \{ B_R, T_R \}$  where  $B_R$  is the base point of the reflection,  $T_R$  is the tipping point of the reflection be two sets with  $(B_O, B_R)$  and  $(T_O, T_R)$  corresponding points. We say that the sets  $X$  and  $Y$  are perspectives from the light source (i.e. Perspective from a point). The following figure shows the physical meaning of PFP in terms of reflection on a mirror. All sets of points on the object and image are perspective from a light source. In a plane mirror the object and the mirror are perspective from the image, mirror and image are PFL.



**Figure 14: Two sets X and Y are Perspective from Light Source**

**Observations**

- From the definitions of PFP and PFL we see that PFP implies PFL (figure 10) but the converse is not true (i.e PFL need not be PFP (figure 12)).
- We see that the concepts of PFL and PFP depends on how the mapping is defined on the given sets of points.
- We also observe how these concepts can be explained based on simple physical facts of projection, reflection and refraction.

**Definition 2.8: Multi Vertexed / Hyper Edge Graph (MVEG)**

Let  $V = \{v_1, v_2, v_3, \dots, v_n\}$  be set of vertices and an 'n' element subset of  $V$  is called an edge with multi-vertices(hyper edge), then the set  $E$  of all such multi-vertex edges (hyper edges) is called the edge set. Then the graph  $G_{MVEG} = (V, E)$  is called a multi-vertexed / hyper edge graph.

**Example 1**

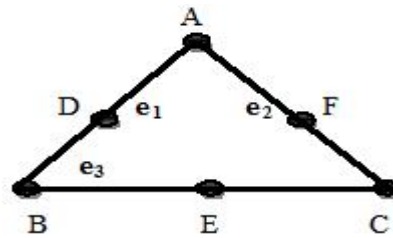

**Figure 15 (a): MVEG with 6 Vertices and 3 Edges**

Here the edge set is  $\{e_1, e_2, e_3\}$  where  $e_1 = (ADB)$ ,  $e_2 = (AFC)$  and  $e_3 = (BEC)$

**Example 2**

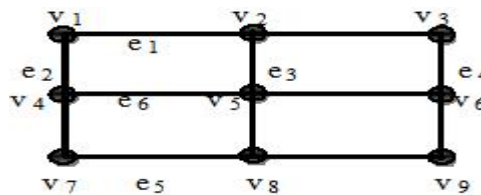

**Figure 15 (b): MVEG with 9 Vertices and 6 Edges**

Here the edge set is  $\{e_1, e_2, e_3, e_4, e_5, e_6\}$  where  $e_1 = (V_1, V_2, V_3)$ ,  $e_2 = (V_1, V_4, V_7)$ ,  $e_3 = (V_2, V_5, V_8)$ ,  $e_4 = (V_3, V_6, V_9)$ ,  $e_5 = (V_7, V_8, V_9)$  and  $e_6 = (V_4, V_5, V_6)$ .

**Note**

In a MVEG , each edge may have 2 (or) 3 (or) 4 (or) n vertices incident on it.

**Definition 2.9: Degree of Multi Vertexed Edge Graph (MVEG)**

Let  $G_{MVEG} = (V, E)$  is a MVEG , if 'v' is a vertex belonging to V, then the degree of the vertex 'v' is denoted as  $d_{MVE}(v)$  and defined as the number of edges incident on it. From example 1 (figure 16 (a)) the degree of the vertices A,B,C,D,E and F are given by  $d_{MVE}(A) = d_{MVE}(B) = d_{MVE}(C) = 2$  and  $d_{MVE}(D) = d_{MVE}(E) = d_{MVE}(F) = 1$ .

**Definition 2.10: Hyper Graph [2]**

A hyper graph H is a pair  $(X, E)$  where X is a set of elements called nodes or vertices and E is a set of non – empty subsets of X called hyper edges or edges.

**Example**

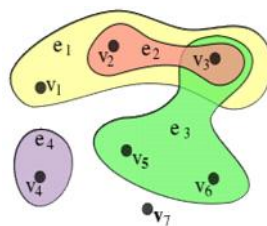

**Figure 16(a): Hyper Graph**



From the above example the vertex set is  $X = \{ V_1, V_2, V_3, V_4, V_5, V_6, V_7 \}$ , the edge set is  $= \{ e_1, e_2, e_3, e_4 \}$  where  $e_1 = \{ V_1, V_2, V_3 \}$ ,  $e_2 = \{ V_2, V_3 \}$ ,  $e_3 = \{ V_3, V_4, V_5, V_6 \}$  and  $e_4 = \{ V_4 \}$ .

**Definition 2.11: Degree of the Hyper Graph**

Let  $H = (X, E)$  is a hyper graph with vertex set  $X$  and edge set  $E$ . If ‘ $v$ ’ is a vertex of  $X$  then the degree of the vertex ‘ $v$ ’ is the number of edges incident on ‘ $v$ ’.

**Definition 2.12: K – Uniform hyper Graph [2]**

A hyper graph in which an edge can connect to ‘ $K$ ’ number of vertices (i.e cardinality of each edge is ‘ $K$ ’) is called  $K$ - uniform hyper graph.

**Example**

The following is an example of a graph with its  $K$ - uniform hyper graph (with  $K = 3$ ). Let  $V = \{ A, B, C, D, E, F \}$  be the vertex set and  $E = \{ e_1, e_2, e_3, e_4, e_5, e_6 \}$  be the edge set with edges  $e_1 = (A, D, B), e_2 = (B, E, C), e_3 = (A, F, C), e_4 = (A, D, F),$

$e_5 = (D, B, F)$  and  $e_6 = (E, C, F)$ . A A

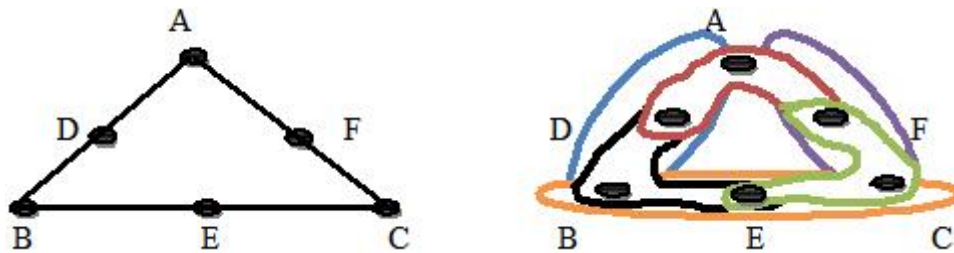

**Figure 16(b): A Graph and its 3- Uniform Hyper Graph**

From the definition of degree of the vertex, the degree of the vertices A,B,C,D,E and F are given by

$$d(A) = d(B) = d(C) = d(D) = d(E) = d(F) = 3.$$

**Observations**

- The multi vertexed/hyper edge graph is not a hyper graph. A hyper graph is a generalization of a graph in which an edge can join any number of vertices where as a multi vertexed /hyper edge is a graph with ‘ $n$ ’ number of vertices incident on each edge . We see that there is a **“Sattle”** difference between them.
- From the definition of multi- vertexed edge we see that its geometrical interpretation is not a straight line or a curve as in the usual definition of an edge. It is difficult to visualize this geometrically. As a result of this some results in graph theory may not work under these new concepts. For example the first theorem in graph theory (The hand shaking lemma) is not applicable for a MVEG. Let us verify the theorem by taking the following example

**Theorem 1: Hand Shaking Lemma [5]**

The theorem states “The sum of the degree of the vertices in a graph  $G = (V, E)$  is twice the number of edges i.e  $\sum degv_i = 2q$  Let us consider a MVEG

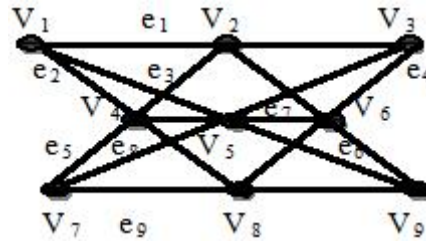

Figure 17: MVEG

**Calculation of Degree for the Given Graph**

Total number of vertices = 9

Total number of edges = 17

Twice the number of edges =  $2 \times 17 = 34$  (1)

$\sum_{i=1}^9 degv_i = 36$  (2)

From equations (1) and (2) we see that  $\sum degv_i \neq 2q$ .

In the view of the definition of multi-vertexed-edge(hyper edge) graph we need to modify theorem 1 as theorem 1.1.

**Theorem 1.1: Hand Shaking Lemma for Multi-Vertexed Edge Graph**

Let  $G = (V, E)$  be a multi-vertexed edge graph and if there are ‘n’ vertices on each of ‘m’ edges then the number of vertices is equal to ‘mn’.

**Calculation of Degree for the Graph (Figure17)**

Total number of vertices = 9

Total number of edges ‘m’ = 9

Total number of vertices on each edge is ‘n’ = 3

The value of  $mn = 3 \times 9 = 27$  (1)

$\sum_{i=1}^9 degv_i = 27$  (2)

From equations (1) and (2) we see that  $\sum degv_i = mn$ . Hence theorem 1.1

**Note:** Theorem 1.1 holds for a MVEG with each edge having the same **cardinality**.

**Section 3**

In this section we interpret configuration, Perspective from a point(PFP) and Perspective from a line (PFL) in terms of graph .

**Definition 3.1 Configuration in Terms of Graph**

Let  $G$  be a graph with ‘ $V$ ’ vertices and ‘ $E$ ’ edges such that ‘ $m$ ’ edges are incident on each of ‘ $V$ ’ vertices and ‘ $n$ ’ vertices lie on each of ‘ $E$ ’ edges. This may be called  $(V_m, E_n)$  graph configuration. To understand this we translate some configurations into their corresponding graphs, the edges are obviously multi-vertexed/hyper edge.

**Example: A  $(6_3, 9_2)$  Configuration**

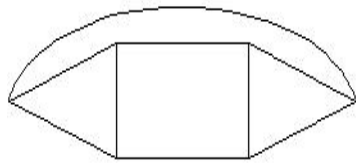

**Figure 18(a): Configuration**

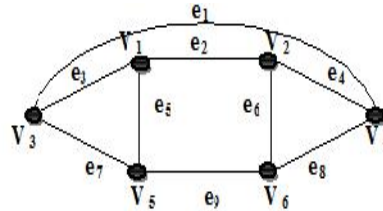

**Graph**

**Note:**

Representation of any  $(p_m, l_n)$  configuration as their corresponding graph, we observe that if on each of ‘ $l$ ’ line if there are  $n > 2$  points incident on them then the resulting graph is a MVEG.

**For Example**

**Example: The Desargues Configuration: A Unique  $10_3$  Configuration**

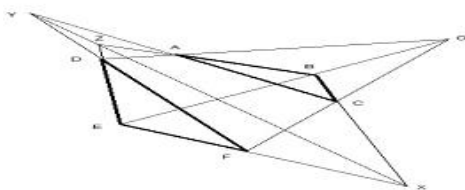

**Figure 18(b): Configuration**

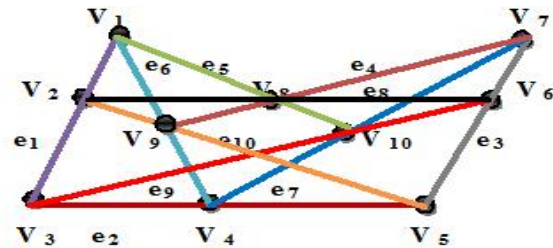

**Graph**

The Desargues configuration is a MVEG with the vertex set  $V = \{V_1, V_2, V_3, V_4, V_5, V_6, V_7, V_8, V_9, V_{10}\}$  and the edge set  $E = \{e_1, e_2, e_3, e_4, e_5, e_6, e_7, e_8, e_9, e_{10}\}$  where  $e_1 = \{V_1, V_2, V_3\}$ ,  $e_2 = \{V_3, V_4, V_5\}$ ,  $e_3 = \{V_5, V_6, V_7\}$ ,  $e_4 = \{V_7, V_8, V_9\}$ ,  $e_5 = \{V_1, V_8, V_{10}\}$ ,  $e_6 = \{V_1, V_9, V_4\}$ ,  $e_7 = \{V_7, V_{10}, V_4\}$ ,  $e_8 = \{V_2, V_8, V_6\}$ ,  $e_9 = \{V_6, V_{10}, V_3\}$  and  $e_{10} = \{V_2, V_9, V_5\}$ .

Following are examples demonstrating as to how given a graph can be represented as its corresponding graph and then translated into its corresponding configuration. In this process the vertices and edges of the graph are represented as the points and lines of their corresponding configuration.

**Example 1**

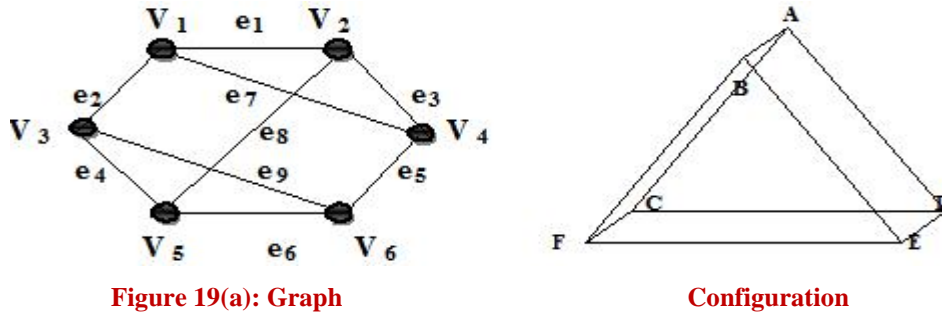
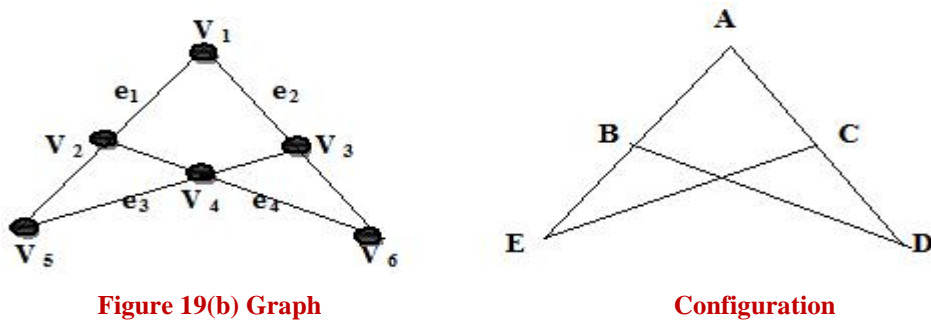

**Figure 19(a): Graph**

**Configuration**

From the figure 19(a) we see that 3 edges intersect at 6 vertices ( $6_3$ ) and 2 vertices lie on each of 9 edges ( $9_2$ ). Thus the given graph can be represented as a  $(6_3, 9_2)$  configuration.

**Example 2**



**Figure 19(b) Graph**

**Configuration**

From the figure 19 (b), we see that 2 edges intersect at 6 vertices ( $6_2$ ) and 3 vertices lie on each of 4 edges ( $4_3$ ). Thus the given graph can be represented as a  $(6_2, 4_3)$  configuration.

From the above examples we can see that given a configuration can be represented as a graph and conversely.

**Definition 3.2: Perspective from a Vertex in a Graph (PFV)**

Let  $G = (V, E)$  be a graph. Let  $G_1 = (V_1, E_1)$  and  $G_2 = (V_2, E_2)$  be two subgraphs of  $G$ . If  $v_1 \in G_1, v_2 \in G_2$  then  $v_1, v_2$  are called corresponding vertices if there is an edge between them. The edge is called the corresponding edge. Let  $V_1 = (a,b,c)$  and  $V_2 = (p,q,r)$  be two vertex sets such that  $G_1$  and  $G_2$  are isomorphic. The corresponding vertices  $(a,p), (b,q)$  and  $(c,r)$  are called corresponding vertices if there exists an edge between the corresponding pair of vertices. We say that the two graphs  $G_1$  and  $G_2$  are PFV 'v' in  $G$  if the corresponding vertices  $(a,p), (b,q)$  and  $(c,r)$  together with 'v' (i.e  $(v,a,p), (v,b,q)$  and  $(v,c,r)$ ) is a multi-vertexed edges (hyper edges) as shown in the figure below. These multi vertexed/hyper edges are called the corresponding edges of the graph  $G$ .

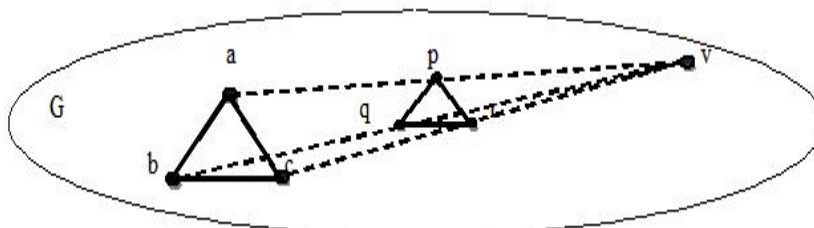

**Figure 20: Two Graphs  $G_1$  and  $G_2$  are PFV 'v'**

**Definition 3.3: Perspective from a Edge in a Graph (PFE)**

The two subgraphs  $G_1$  and  $G_2$  of  $G$  with corresponding vertices are said to be PFE ‘e’ if the corresponding edges meet at different vertices on an edge ‘e’ in  $G$ . This edge ‘e’ is a multi vertexed /hyper edge.

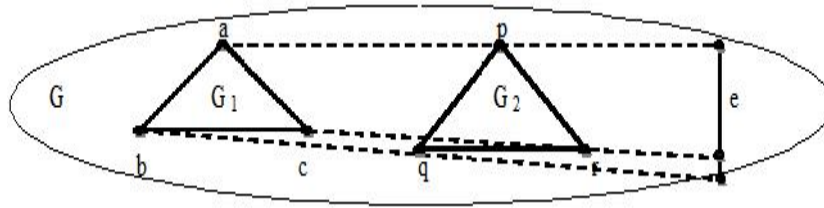

**Figure 21: Two Graphs  $G_1$  and  $G_2$  are PFE ‘e’**

**Observation**

We see that the definitions, PFL and PFP in terms of graph results in a MVEG

**Section 4**

In this section we translate the concepts of configuration, Perspective from a point(PFP) and Perspective from a line (PFL) in terms of electrical network/circuit.

**Electrical Configuration (Network Topology)**

An electrical configuration (or) network topology is an arrangement of ‘T’ terminals and ‘C’ electrical components on a circuit board such that ‘m’ components are equipped between each of ‘T’ terminals and ‘n’ terminals connect each of ‘C’ components. The electrical configuration is denoted as  $(T_m, C_n)$  electrical configuration.

**Example: A  $4_2$  Configuration**

A  $4_2$  electrical Configuration is a configuration with 4 components intersecting at each of 2 terminals ( $4_2$ ) and 2 terminals connect each of 4 components ( $4_2$ ).

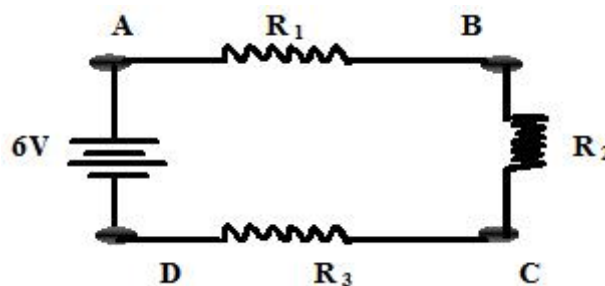
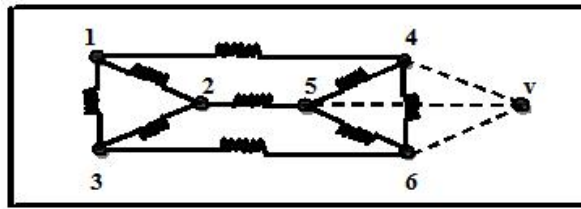

**Figure 22: A  $4_2$  Electrical Configuration**

A circuit consists of several sections like audio, video, power supply, etc. These are called modules. *Two modules are isomorphic if there have same number of terminals and components.*

**Perspective from a Terminal in a Circuit (PFT)**

Let us consider a circuit C. Let  $C_1 = \{1, 2, 3\}$  and  $C_2 = \{4, 5, 6\}$  be two isomorphic modules. The pair of terminals (1,4), (2,5) and (3,6) are said to be corresponding points (terminals) if the pair of terminals are connected with an electrical component . We say that the circuits  $C_1$  and  $C_2$  are PFT ‘v’ if the electrical components are said to be connected in series.



**Figure 23 (a): Two Set of Terminals are PFT 'v'**

**Perspective from a Cable in a Circuit (PFC)**

We say that the two modules  $C_1$  and  $C_2$  of the circuit  $C$  with corresponding points(terminals) are PFC 'l' if the corresponding line are connected in parallel at different terminals on 'l' as shown in the figure.

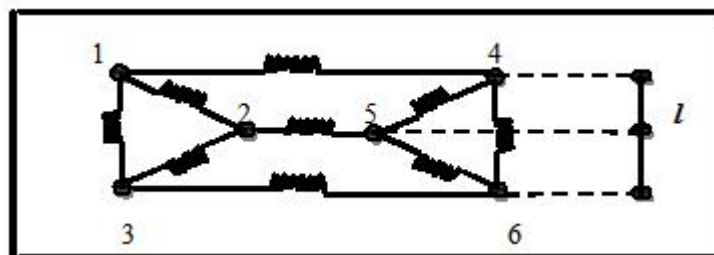
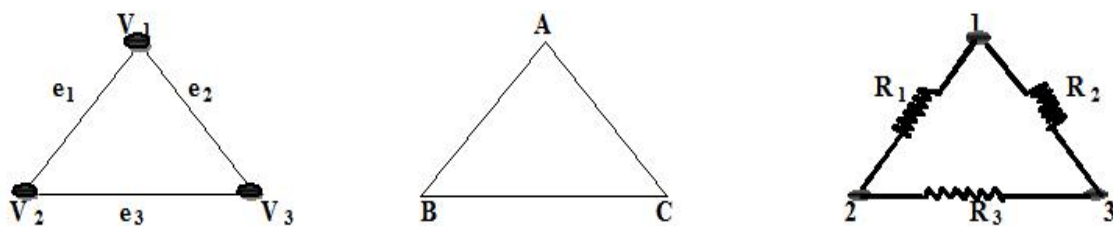

**Figure 23(b): Two Set of Terminals are PFC 'l'**

In section 3, we have seen that how a given configurations can be represented in terms of graphs and conversely. Following are some example illustrating how a given configuration can be represented as its corresponding configuration and then translated to its corresponding circuits

**Example Demonstrating Translation of Graph to its Corresponding Configuration and then to its Corresponding Electrical Network/Circuit**

Now, let us consider a simple graph with three vertices and three edges. This simple graph represents a  $3_2$  configuration and this  $3_2$  configuration represents a  $3_2$  electrical configuration (star topology) as shown below



**Figure 24: Graph**

**Configuration**

**Circuit**

Now let us demonstrate how a single configuration can be used to represent many electrical network/circuit.

**Note**

From the above example, we observe that a single configuration results in many electrical circuit/networks.

**Example Demonstrating Translation of an Electrical Network/Circuit to its Corresponding Graph and then to its Corresponding Configuration**

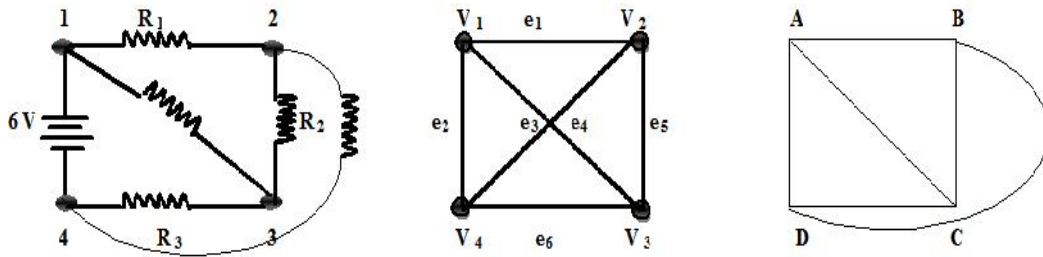

**Figure 25: Circuit**

**Graph**

**Configuration**

**Note**

- Thus the above examples show that how configuration finds its natural application to circuit theory.
- We see that for any  $n_1$  configuration, is a resistor (or capacitor, inductor, diode or a battery (source)) when  $n = 2$ , a transistor when  $n = 3$  and an IC when  $n > 3$ . Hence for  $n_1$  configuration, if  $n \geq 3$  the resulting graph is a MVEG and the electrical circuit representing this MVEG is a network of electrical components with transistors or IC's

**Section 5**

In this section, we see the application of Desargues (10<sub>3</sub>) configuration to circuit theory.

As seen in earlier section the representation of Desargues (10<sub>3</sub>) configuration in terms of graph results in a MVEG. Hence the translation of a MVEG to an electrical network/ circuit is a network of resistors, inductors, capacitors, transistors or IC's. We know that transistors are semiconductors mainly used in electronic circuits as voltage and power amplifiers (amplifiers is an electronic device which basically boost up the strength of a weak signal and convert it to strong signal). They are also used as switches in various circuits.

Now let us see how a circuit can be built for the Desargues (10<sub>3</sub>) configuration.

**The Desargues Configuration: A Unique 10<sub>3</sub> Configuration**

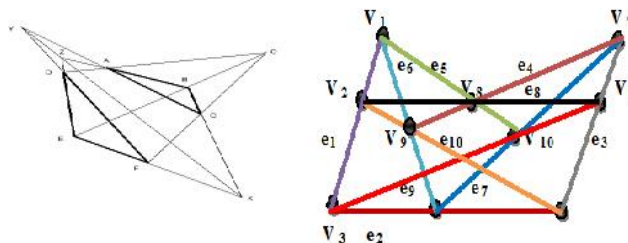

**Figure 26 (a): Configuration**

**Graph**



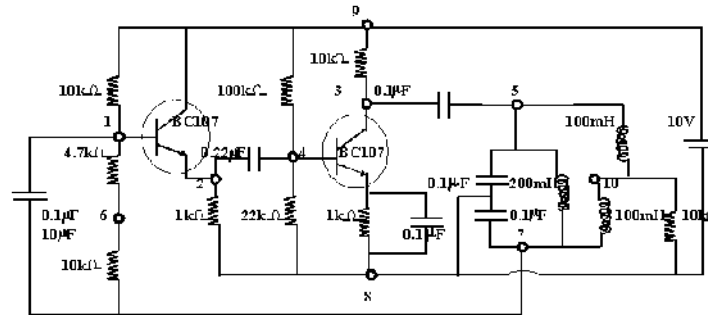

The following is the electrical network/circuit (design layout) built for Desargues ( $10_3$ ) configuration.

**Figure 26 (b): Boot Strapped Emitter Follower as Colpitt's Oscillator**

The following represents the model of the designed electrical network/circuit and its corresponding wave form built for the Desargues ( $10_3$ ) configuration

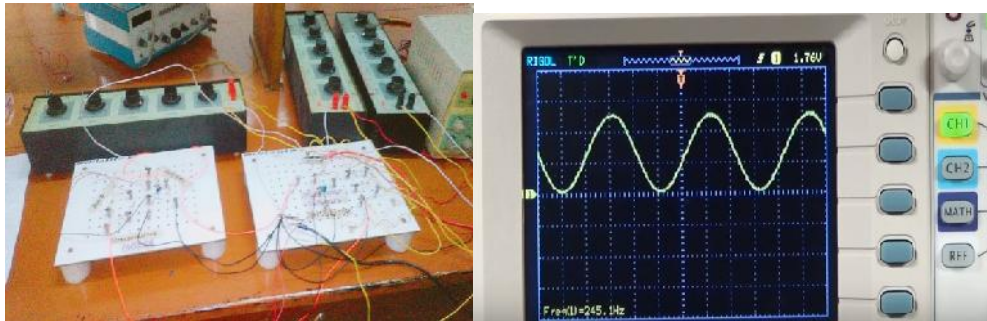

**Figure 27 (c) Boot Strapped Emitter Follower as Colpitt's Oscillator Circuit**

We observe here that the Desargues ( $10_3$ ) configuration results in “Boot strapped emitter follower as Colpitt’s oscillator” circuit. The main purpose of Boot strapped circuit[7] is to increase the input impedance (measure of the opposition that the circuit presents to a current when a voltage is applied) and the distinguish feature of Colpitt’s oscillator is that the feedback for the active device is taken from a voltage divider made of two capacitors in series across the inductor. The “Boot strapped emitter follower as Colpitt’s oscillator” circuit is used for the generation of the sinusoidal output signal with very high frequency. As a result of this property the circuit find its useful application for the development of mobile and radio communication and for many other commercial purposes.

#### Note

The same Desargues ( $10_3$ ) configuration can be translated into many electrical circuits for different application by changing the electrical components.

#### REFERENCES

1. Alexander, C.K., Sadiku, M, N., *Fundamental of electric circuit*, New York, MaGraw – Hill, 2004.
2. Berge.Claude.,: *Hyper graphs and Combinatorics of finite sets*, North Holland mathematical library., Elsevier Science publishers.B.V.,1989.
3. Coxeter, H.S.M., *Desargues configuration and their collinearation groups.Math proc.Cambridge Philos.Soc.*78(1975),15-16.
4. Frank Harary, *Graph theory*, Addison – Wesley, MA, 1969.



5. *Hareld Gropp,,: Configuration between geometry and Combinatorics, Discrete Applied Mathematics, vol 138, Issues 1-2,29 march 2004,pages 79-88.*
6. *Theraja, B ,L,,: Basic electronics, First edition, S.Chand & company Ltd, 2012.*

